

METAL PLATE CURRENT SENSING MILLIOHM CHIP TLRH

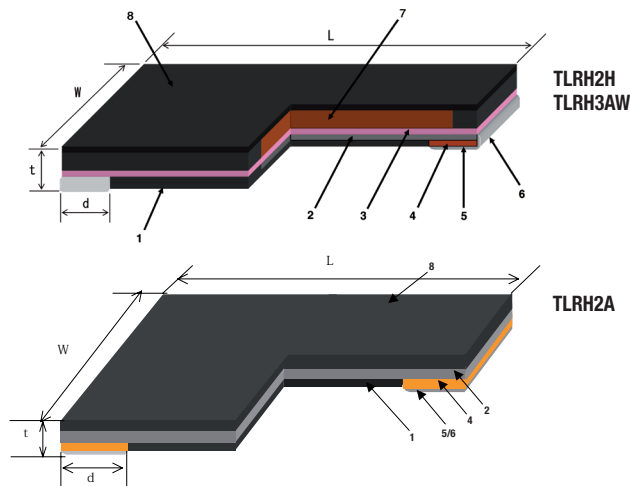

STRUCTURE

- 1 Bottom protective coating
- 2 Resistive element
- 3 Insulation
- 4 Inner electrode
- 5 Nickel plating
- 6 Solder Plating
- 7 Metal plate carrier
- 8 Top protective coating

IDENTIFICATION

PRODUCT CODE	COATING	MARKING
TLRH 2A	Black protective top coating	No marking
TLRH 2H, TLRH 3AW		4 digits

All these products have Pb-free terminations and meet EU-RoHS and China-RoHS requirements

TYPE DESIGNATION (HOW TO ORDER)

TLRH	3AW	T	TE	R100	F
PRODUCT CODE TLRH	POWER RATING 2A: 0.25W 2H: 1W 3AW: 2W	TERMINAL MATERIAL T: Sn	TAPING* TE: embossed plastic tape BK: Bulk	NOMINAL RESISTANCE F: 4 digits	RESISTANCE TOLERANCE F: (±1%)

Contact us when you have control request for environmental hazardous material other than the substance specified by EU-RoHS

FEATURES

- High power rating 2W in 2512 size
- High reliability and performance with resistance tolerance ±1% and T.C.R. ±50ppm/K (2A: ±75ppm/K)
- Ultra low height with a thickness of 0.5mm
- Carrier metal plate inside, resistor of high radiation of heat structure
- Suitable for use in small equipment
- Automatic mounting machine is applicable
- Ideal to use for current detecting of motor control, power supply, PC application, etc.
- Meets or exceeds IEC 60115-1, JIS C 5201-1, EIAJ RC-2134B
- Suitable for reflow soldering
- Terminal temperature: +105°C

DIMENSIONS (mm)

TYPE	RESISTANCE (Ω)	L	W	d	t
TLRH 2A**	10 mΩ...100 mΩ	2.0 ± 0.2	1.25 ± 0.2	0.35 ± 0.2	0.25 ± 0.15
TLRH 2H	33 mΩ...250 mΩ	5.0 ± 0.2	2.5 ± 0.2	0.5 ± 0.2	0.5 ± 0.2
TLRH 3AW	22 mΩ...150 mΩ	6.3 ± 0.2	3.2 ± 0.2	0.75 ± 0.2	0.5 ± 0.2

**Under development

DERATING CURVE

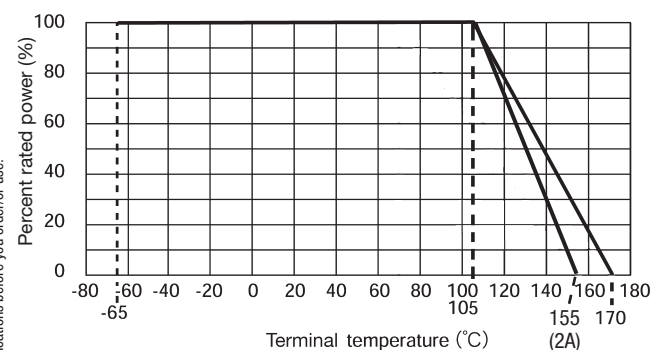

TEMPERATURE RISE

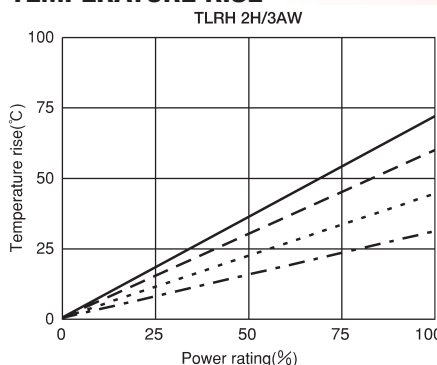

Regarding the temperature rise, the value of the temperature varies per conditions and board for use since the temperature is measured under our measuring conditions. Please refer to us before use.

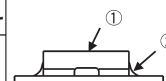

RATING

SIZE	TYPE	T.C.R. (ppm/K)	POWER RATING*	RESISTANCE RANGE (Ω) E12	RESISTANCE TOLERANCE	TERMINAL TEMP. UNDER A RATED LOAD	OPERATING TEMP. RANGE
0805	TLRH 2A**	±75	0.25 W	10 mΩ...100 mΩ			-65°C...+155°C
2010	TLRH 2H	±50	1.0 W	33 mΩ...250 mΩ	F (±1%)	+105°C and less	-65°C...+170°C
2512	TLRH 3AW	±50	2.0 W	22 mΩ...150 mΩ			

* For resistors operated at terminal temperatures of +105°C or above, the power rating shall be derated in accordance with the shown "DERATING CURVE".

Rated voltage = √Power rating x resistance value

** Under development

Precautions:

If these low ohm resistors are used as shunt resistors, please lay out a pattern considering the electromagnetic induction with surrounding inductors. Please note during design, that the voltage drop over these low ohm resistors is dependant on the PCB-layout, the shape and size of the pad pattern, the solder amount and the measuring points.

Please contact KOA for further performance characteristics and order the technical specification for this product before you order and use this series.

Contact our sales representatives before you use our products for applications including automobiles, medical equipment and aerospace equipment. Malfunction or failure of the products in such applications may cause loss of human life or serious damage.

Specifications given herein may be changed at any time without prior notice. Please confirm technical specifications before you order or use.

LOW OHM