

FERRITE CORE POWER INDUCTOR LPC 9040N LPC 9040E

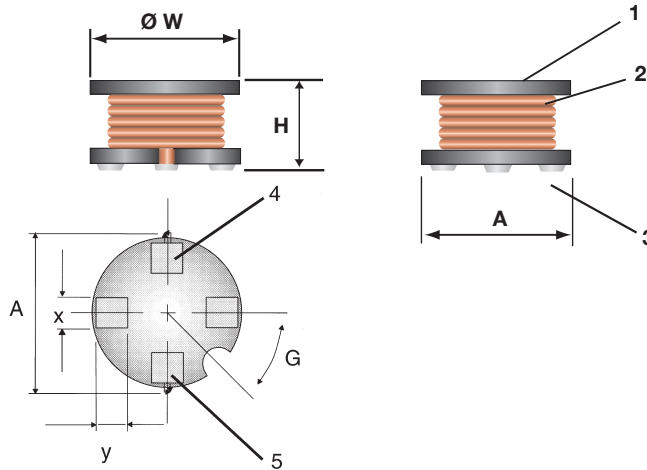

STRUCTURE

- 1 Ferrite core
- 2 Winding wire
- 3 Electrode
- 4 Terminal 1
- 5 Terminal 2

IDENTIFICATION

PRODUCT CODE	COATING COLOR	MARKING
LPC 9040N LPC 9040E	Clear	None

Products with Pb-free terminations meet EU-RoHS requirements

TYPE DESIGNATION (HOW TO ORDER)

LPC 9040E	A	TE	470	K
PRODUCT CODE LPC 9040N LPC 9040E	TERMINATION SURFACE MATERIAL A: SnAg (L: Sn/Pb)	TAPING* TE: 1.500 pcs/reel BK: Bulk = 100 pcs *Please see "PACKAGING"	NOMINAL INDUCTANCE 3 digits (Unit: μ H)	INDUCTANCE TOLERANCE K: ($\pm 10\%$) M: ($\pm 20\%$)

Contact us when you have control request for environmental hazardous material other than the substance specified by EU-RoHS

FEATURES

- Large permissible DC current and small DC resistance are realized by the original construction and wiring technology
- Automatic surface mounting is applicable
- Excellent solderability and endurance environment
- LPC 9040N = Operating temperature range: $-40^{\circ}\text{C} \dots +85^{\circ}\text{C}$
- LPC 9040E = Operating temperature range: $-40^{\circ}\text{C} \dots +125^{\circ}\text{C}$
- Suitable for reflow soldering
- Embossed carrier tape packaging available

DIMENSIONS (mm)

TYPE	$\varnothing W$	$H_{(\text{max.})}$	$A_{(\text{max.})}$	x	y	G
LPC9040	9.0 ± 0.1	4.9	10.2	2.0 ± 0.2	1.8 ± 0.2	$45^{\circ} \pm 6^{\circ}$

RATING

TYPE	INDUCTANCE		INDUCTANCE MEASURING FREQUENCY	SELF-RESONANT FREQUENCY (MIN.)	DC RESISTANCE (MAX.)	ALLOWABLE DC CURRENT (MAX.)		
	NOM. VALUE*	TOLERANCE						
LPC 9040N □ TE 100 M	10 μ H	M ($\pm 20\%$)	1 kHz	25.0 MHz	0.07 Ω	1.55 A		
LPC 9040N □ TE 150 K	15 μ H	K ($\pm 10\%$)		21.0 MHz	0.09 Ω	1.40 A		
LPC 9040N □ TE 220 K	22 μ H			15.0 MHz	0.11 Ω	1.25 A		
LPC 9040N □ TE 330 K	33 μ H			13.5 MHz	0.14 Ω	1.10 A		
LPC 9040N □ TE 470 K	47 μ H			11.5 MHz	0.20 Ω	0.99 A		
LPC 9040N □ TE 680 K	68 μ H			10.0 MHz	0.27 Ω	0.91 A		
LPC 9040N □ TE 101 K	100 μ H			8.0 MHz	0.41 Ω	0.70 A		
LPC 9040N □ TE 151 K	150 μ H			7.0 MHz	0.55 Ω	0.60 A		
LPC 9040N □ TE 221 K	220 μ H			5.0 MHz	0.81 Ω	0.50 A		
LPC 9040N □ TE 331 K	330 μ H			3.3 MHz	1.86 Ω	0.29 A		
LPC 9040N □ TE 471 K	470 μ H			2.8 MHz	2.07 Ω	0.22 A		
LPC 9040N □ TE 681 K	680 μ H			1.2 MHz	2.65 Ω	0.14 A		
LPC 9040E □ TE 100 M	10 μ H			M ($\pm 20\%$)	1 kHz	25.0 MHz	0.07 Ω	2.40 A
LPC 9040E □ TE 150 K	15 μ H			K ($\pm 10\%$)		21.0 MHz	0.09 Ω	2.20 A
LPC 9040E □ TE 220 K	22 μ H		15.0 MHz			0.11 Ω	2.00 A	
LPC 9040E □ TE 330 K	33 μ H	13.5 MHz	0.14 Ω			1.80 A		
LPC 9040E □ TE 470 K	47 μ H	11.5 MHz	0.20 Ω			1.40 A		
LPC 9040E □ TE 680 K	68 μ H	10.0 MHz	0.27 Ω			1.20 A		
LPC 9040E □ TE 101 K	100 μ H	8.0 MHz	0.41 Ω			1.00 A		
LPC 9040E □ TE 151 K	150 μ H	7.0 MHz	0.55 Ω			0.80 A		
LPC 9040E □ TE 221 K	220 μ H	5.0 MHz	0.81 Ω			0.60 A		
LPC 9040E □ TE 331 K	330 μ H	3.3 MHz	1.86 Ω			0.45 A		
LPC 9040E □ TE 471 K	470 μ H	2.8 MHz	2.07 Ω			0.40 A		
LPC 9040E □ TE 681 K	680 μ H	1.2 MHz	2.65 Ω			0.35 A		

* Other inductance values on request □ Enter the code for termination surface material (A, L)

Avoid strong pressure or excessive shock at mounting or after mounting because electric/magnetic characteristics may change if it is applied to the inductors.

Contact our sales representatives before you use our products for applications including automobiles, medical equipment and aerospace equipment. Malfunction or failure of the products in such applications may cause loss of human life or serious damage.

Specifications given herein may be changed at any time without prior notice. Please confirm technical specifications before you order or use.

INDUCTORS