

**FERRITE CORE
POWER INDUCTOR
LPC 10065**

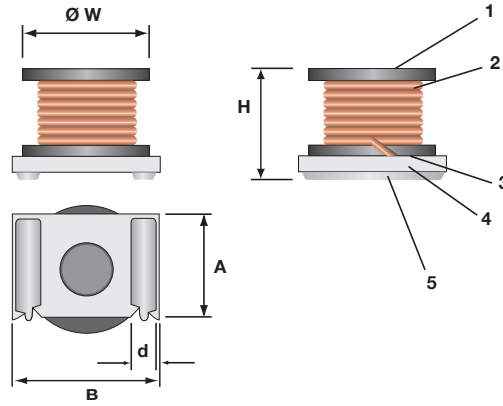

STRUCTURE

- 1 Ferrite core
- 2 Winding wire
- 3 Epoxy adhesive
- 4 Ceramic substrate
- 5 Electrode

IDENTIFICATION

PRODUCT CODE	COATING COLOR	MARKING
LPC 10065	Clear	None

Products with Pb-free terminations meet EU-RoHS requirements

TYPE DESIGNATION (HOW TO ORDER)

LPC 10065	A	TE	221	K
PRODUCT CODE	TERMINATION SURFACE MATERIAL A: SnAg (L: Sn/Pb)	TAPING* TE: 500 pcs/reel BK: Bulk = 100 pcs (L: Sn/Pb) *Please see "PACKAGING"	NOMINAL INDUCTANCE 3 digits (Unit: μH)	INDUCTANCE TOLERANCE K: ($\pm 10\%$) M: ($\pm 20\%$)

Contact us when you have control request for environmental hazardous material other than the substance specified by EU-RoHS

FEATURES

- Large permissible DC current and small DC resistance are realized by the original construction and wiring technology
- Automatic surface mounting is applicable
- Excellent solderability and endurance environment
- Suitable for reflow soldering
- Embossed carrier tape packaging available
- Operating temperature range*: -40° C ... +85° C
- Inductors for extended operating temperature range* (-40° C ... +125° C) in the range 47 μH ... 3.3mH on request

* Including self-temperature rise

DIMENSIONS (mm)

PRODUCT CODE	Ø W	H	A	B	d
LPC 10065	10.0 \pm 0.2	7.5 max.	8.0 \pm 0.2	10.4 \pm 0.2	2.5 \pm 0.2

RATING

TYPE	INDUCTANCE		INDUCTANCE MEASURING FREQUENCY	SELF-RESONANT FREQUENCY (MIN.)	DC RESISTANCE (MAX.)	ALLOWABLE DC CURRENT (MAX.)
	NOM. VALUE*	TOLERANCE				
LPC 10065 □ TE R68 M	0.68 μH	M ($\pm 20\%$)	1 MHz	75.0 MHz	0.006 Ω	9.50 A
LPC 10065 □ TE 1R0 M	1.0 μH			65.0 MHz	0.007 Ω	9.00 A
LPC 10065 □ TE 1R5 M	1.5 μH			50.0 MHz	0.008 Ω	8.50 A
LPC 10065 □ TE 2R2 M	2.2 μH			40.0 MHz	0.009 Ω	7.50 A
LPC 10065 □ TE 3R3 M	3.3 μH			30.0 MHz	0.012 Ω	6.80 A
LPC 10065 □ TE 4R7 M	4.7 μH			25.0 MHz	0.017 Ω	5.70 A
LPC 10065 □ TE 6R8 M	6.8 μH			20.0 MHz	0.024 Ω	4.70 A
LPC 10065 □ TE 100 K	10 μH			15.0 MHz	0.036 Ω	3.90 A
LPC 10065 □ TE 150 K	15 μH			12.0 MHz	0.054 Ω	3.15 A
LPC 10065 □ TE 220 K	22 μH			9.00 MHz	0.080 Ω	2.60 A
LPC 10065 □ TE 330 K	33 μH			8.00 MHz	0.120 Ω	2.30 A
LPC 10065 □ TE 470 K	47 μH			6.00 MHz	0.175 Ω	1.79 A
LPC 10065 □ TE 680 K	68 μH			5.00 MHz	0.255 Ω	1.48 A
LPC 10065 □ TE 101 K	100 μH			4.00 MHz	0.38 Ω	1.22 A
LPC 10065 □ TE 151 K	150 μH			3.00 MHz	0.58 Ω	1.00 A
LPC 10065 □ TE 221 K	220 μH	2.50 MHz	0.85 Ω	0.82 A		
LPC 10065 □ TE 331 K	330 μH	2.00 MHz	1.30 Ω	0.67 A		
LPC 10065 □ TE 471 K	470 μH	1.50 MHz	1.85 Ω	0.57 A		
LPC 10065 □ TE 681 K	680 μH	1.00 MHz	2.70 Ω	0.47 A		
LPC 10065 □ TE 102 K	1000 μH	0.95 MHz	4.00 Ω	0.38 A		
LPC 10065 □ TE 152 K	1500 μH	0.85 MHz	6.10 Ω	0.31 A		
LPC 10065 □ TE 222 K	2200 μH	0.70 MHz	9.00 Ω	0.26 A		
LPC 10065 □ TE 332 K	3300 μH	0.55 MHz	13.50 Ω	0.21 A		

* Other inductance values on request □ Enter the code for termination surface material (A, L)

Avoid strong pressure or excessive shock at mounting or after mounting because electric/magnetic characteristics may change if it is applied to the inductors.

Contact our sales representatives before you use our products for applications including automobiles, medical equipment and aerospace equipment. Malfunction or failure of the products in such applications may cause loss of human life or serious damage.

Specifications given herein may be changed at any time without prior notice. Please confirm technical specifications before you order/use.