

**AIR CORE  
WIREWOUND  
CHIP INDUCTOR  
KQ 0805**

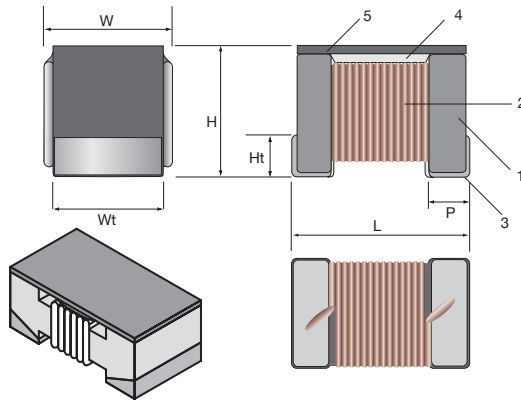
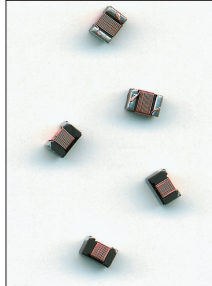

**STRUCTURE**

- 1 Ceramic core
- 2 Winding wire
- 3 Electrode
- 4 Inner coat
- 5 Flat top film

**IDENTIFICATION**

PRODUCT CODE	BODY COLOR	MARKING
KQ 0805	Black	1 digit

All these products have Pb-free terminations and meet EU-RoHS requirements

**TYPE DESIGNATION (HOW TO ORDER)**

KQ0805	T	TE	R10	J
PRODUCT CODE	TERMINATION SURFACE MATERIAL T: Sn	TAPING* TE, BK <small>*Please see "PACKAGING"</small>	NOMINAL INDUCTANCE 3 digits code (see below)	INDUCTANCE TOLERANCE G: (±2%) J: (±5%) K: (±10%)

Contact us when you have control request for environmental hazardous material other than the substance specified by EU-RoHS

**FEATURES**

- Small chip inductors of air-core (wirewound type)
- High Q and high self-resonant frequency
- Low DC resistance and high allowable DC current
- Excellent mountability, solderability and high reliability
- Suitable for high-frequency circuits in telecommunication equipment and mobile phones
- Parts are tested according to AEC-Q200 requirements
- Operating temperature range: - 40° C ... + 125° C
- Flat top suitable for high speed mounting
- Suitable for reflow soldering
- Lab Kit available

**DIMENSIONS (mm)**

PRODUCT CODE	L	W*	H	Wt	Ht	P
KQ0805	2.0 ± 0.2	1.x ± 0.2	1.3 ± 0.2	1.35 ± 0.1	0.40 ± 0.15	0.45 ± 0.1
	*1.5 ± 0.2 (3.3nH ... 390nH) 1.6 ± 0.2 (470nH ... 820nH)					

**TYPICAL FREQUENCY CHARACTERISTICS**

Test equipment: Agilent 4291A impedance analyzer

**INDUCTANCE vs. FREQUENCY**

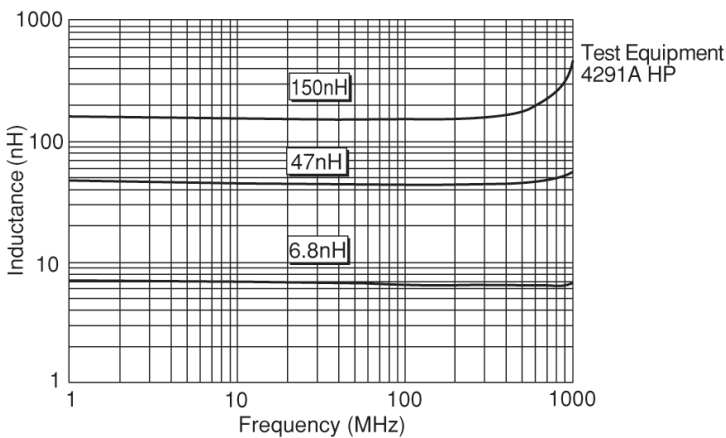

**Q-FACTOR vs. FREQUENCY**

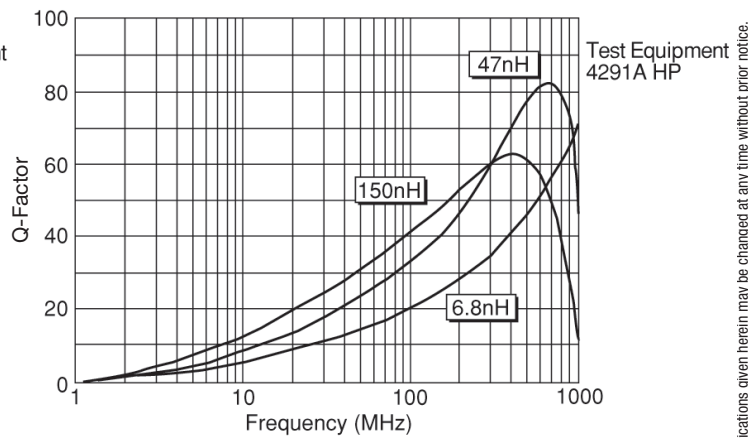

Contact our sales representatives before you use our products for applications including automobiles, medical equipment and aerospace equipment. Malfunction or failure of the products in such applications may cause loss of human life or serious damage.

Specifications given herein may be changed at any time without prior notice. Please confirm technical specifications before you order/use.

## AIR CORE WIREWOUND CHIP INDUCTOR KQ 0805

### RATING

TYPE	MARKING	INDUCTANCE			QUALITY FACTOR		SELF-RESONANT FREQUENCY (MIN.)	DC RESISTANCE (MAX.)	ALLOWABLE DC CURRENT (MAX.)					
		NOM. VALUE	FREQUENCY	TOLERANCE	Q (MIN.)	FREQUENCY								
KQ0805 T TE 3N3 □	0	3.3 nH	250 MHz	J (±5%) K (±10%)	50	1500 MHz	6000 MHz	0.08 Ω	600 mA					
KQ0805 T TE 6N8 □	1	6.8 nH				1000 MHz	5500 MHz	0.11 Ω						
KQ0805 T TE 8N2 □	2	8.2 nH				4700 MHz	0.12 Ω							
KQ0805 T TE 12N □	3	12 nH		4000 MHz		0.15 Ω	50							
KQ0805 T TE 15N □	4	15 nH		3400 MHz		0.17 Ω								
KQ0805 T TE 18N □	5	18 nH		3300 MHz		0.20 Ω								
KQ0805 T TE 20N □	Y	20 nH		200 MHz		G (±2%) J (±5%) K (±10%)	60	2600 MHz		0.22 Ω	500 mA			
KQ0805 T TE 22N □	6	22 nH						500 MHz		2500 MHz		0.25 Ω		
KQ0805 T TE 27N □	7	27 nH						2050 MHz		0.27 Ω				
KQ0805 T TE 33N □	8	33 nH	2000 MHz		0.29 Ω	65								
KQ0805 T TE 39N □	9	39 nH	1650 MHz		0.34 Ω									
KQ0805 T TE 43N □	4	43 nH	1550 MHz		0.34 Ω									
KQ0805 T TE 47N □	0	47 nH	150 MHz		J (±5%) K (±10%)	50		1450 MHz	0.38 Ω	400 mA				
KQ0805 T TE 56N □	1	56 nH						1300 MHz	0.42 Ω					
KQ0805 T TE 68N □	2	68 nH						1200 MHz	0.46 Ω					
KQ0805 T TE 82N □	3	82 nH		100 MHz	G (±2%) J (±5%) K (±10%)		50	1100 MHz	0.51 Ω		350 mA			
KQ0805 T TE R10 □	4	100 nH						920 MHz	0.56 Ω					
KQ0805 T TE R12 □	5	120 nH						870 MHz	0.64 Ω					
KQ0805 T TE R15 □	6	150 nH			250 MHz			G (±2%) J (±5%) K (±10%)	50			850 MHz	0.70 Ω	310 mA
KQ0805 T TE R16 □	H	160 nH										650 MHz	1.0 Ω	
KQ0805 T TE R17 □	J	170 nH										600 MHz	1.4 Ω	
KQ0805 T TE R18 □	7	180 nH	50 MHz			G (±2%) J (±5%) K (±10%)		33		560 MHz		1.5 Ω	290 mA	
KQ0805 T TE R19 □	D	190 nH								375 MHz		1.76 Ω		
KQ0805 T TE R20 □	E	200 nH								340 MHz		1.9 Ω		
KQ0805 T TE R21 □	F	210 nH		25 MHz		G (±2%) J (±5%) K (±10%)	23			188 MHz	2.2 Ω	190 mA		
KQ0805 T TE R22 □	8	220 nH								215 MHz	2.35 Ω			
KQ0805 T TE R23 □	K	230 nH								180 mA				
KQ0805 T TE R24 □	L	240 nH			50 MHz	G (±2%) J (±5%) K (±10%)			48	600 MHz	1.4 Ω			310 mA
KQ0805 T TE R25 □	6	250 nH								560 MHz	1.5 Ω			
KQ0805 T TE R27 □	9	270 nH								375 MHz	1.76 Ω			
KQ0805 T TE R33 □	0	330 nH	25 MHz			G (±2%) J (±5%) K (±10%)		23		340 MHz	1.9 Ω		230 mA	
KQ0805 T TE R39 □	1	390 nH								188 MHz	2.2 Ω			
KQ0805 T TE R47 □	2	470 nH								215 MHz	2.35 Ω			
KQ0805 T TE R56 □	3	560 nH		25 MHz		G (±2%) J (±5%) K (±10%)	23			180 mA				
KQ0805 T TE R68 □	4	680 nH								180 mA				
KQ0805 T TE R82 □	5	820 nH								180 mA				

□ Enter the code for inductance tolerance (G, J, K)

TE = 2.000 pcs/reel

Please note, that the pattern and size of the pads may affect the Q-values. Please verify the actual using conditions.

Contact our sales representatives before you use our products for applications including automobiles, medical equipment and aerospace equipment. Malfunction or failure of the products in such applications may cause loss of human life or serious damage.  
 Specifications given herein may be changed at any time without prior notice. Please confirm technical specifications before you order or use.

INDUCTORS