

**AIR CORE  
WIREWOUND  
CHIP INDUCTOR  
KQ 0603**

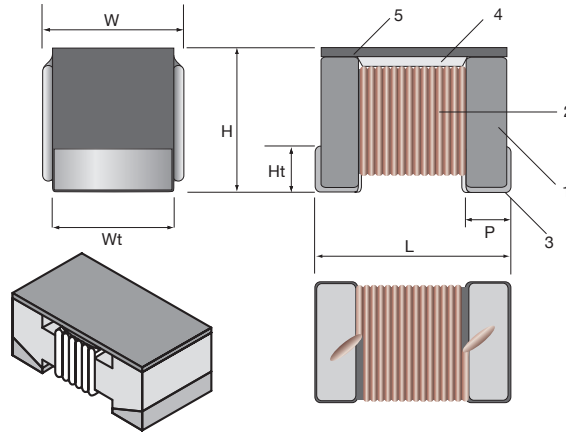

**STRUCTURE**

- 1 Ceramic core (Ferrit content at  $L \geq 330\text{nH}$ )
- 2 Winding wire
- 3 Electrode
- 4 Inner coat
- 5 Flat top film

**IDENTIFICATION**

PRODUCT CODE	BODY COLOR	MARKING
KQ 0603	Black	1 digit

All these products have Pb-free terminations and meet EU-RoHS requirements

**TYPE DESIGNATION (HOW TO ORDER)**

KQ0603	T	TE	R10	J
PRODUCT CODE	TERMINATION SURFACE MATERIAL T: Sn	TAPING* TE, BK  *Please see "PACKAGING"	NOMINAL INDUCTANCE 3 digits code (see rating table)	INDUCTANCE TOLERANCE G: ( $\pm 2\%$ ) J: ( $\pm 5\%$ ) K: ( $\pm 10\%$ )

Contact us when you have control request for environmental hazardous material other than the substance specified by EU-RoHS

**FEATURES**

- Small chip inductors of air-core (wirewound type)
- High Q and high self-resonant frequency
- Low DC resistance and high allowable DC current
- Excellent mountability, solderability and high reliability
- Suitable for high-frequency circuits in telecommunication equipment and mobile phones
- Parts are tested according to AEC-Q200 requirements
- Operating temperature range:  $-40^{\circ}\text{C} \dots +125^{\circ}\text{C}$
- Flat top suitable for high speed mounting
- Suitable for reflow soldering
- Lab Kit available

**DIMENSIONS (mm)**

PRODUCT CODE	L	W	H	Wt	Ht	P
KQ0603	$1.6 \pm 0.1$	$1.0 \pm 0.1$	$0.9 \pm 0.1$	$0.85 \pm 0.1$	$0.25 \pm 0.15$	$0.35 \pm 0.1$

**TYPICAL FREQUENCY CHARACTERISTICS**

Test equipment: Agilent 4291A impedance analyzer

**INDUCTANCE vs. FREQUENCY**

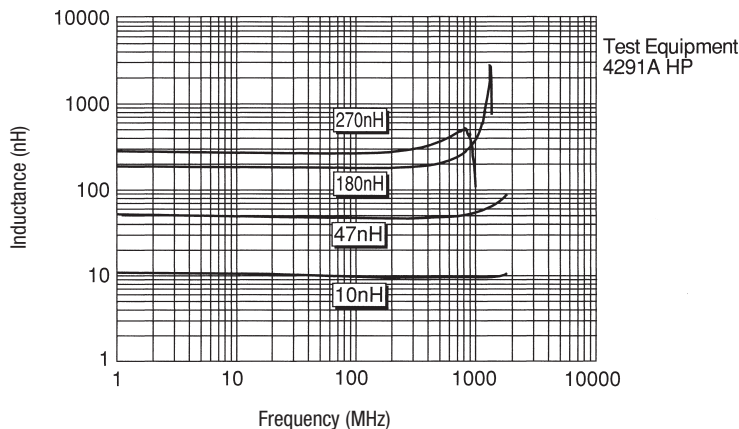

**Q-FACTOR vs. FREQUENCY**

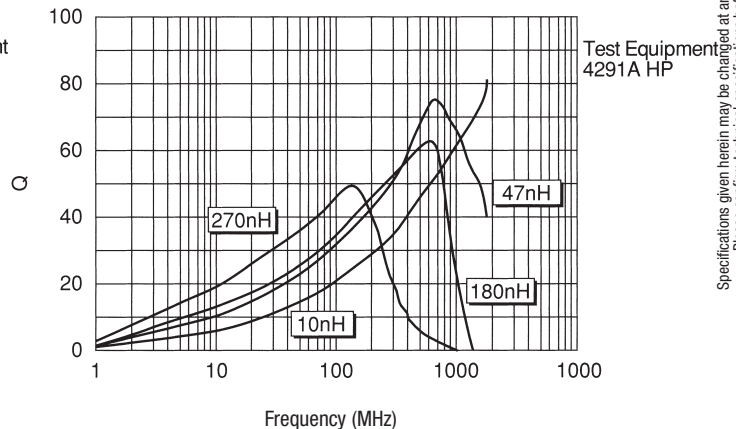

Contact our sales representatives before you use our products for applications including automobiles, medical equipment and aerospace equipment. Malfunction or failure of the products in such applications may cause loss of human life or serious damage.

Specifications given herein may be changed at any time without prior notice. Please confirm technical specifications before you order/use.

## AIR CORE WIREWOUND CHIP INDUCTOR, KQ 0603

### RATING

TYPE	MARKING	NOMINAL INDUCTANCE	INDUCTANCE TOLERANCE	QUALITY FACTOR (MIN.)	SELF-RESONANT FREQUENCY (MIN.)	DC RESISTANCE (MAX.)	ALLOWABLE DC CURRENT (MAX.)	L/Q-MEASURING FREQUENCY							
KQ0603 T TE 1N6 □	C	1.6 nH	J (±5%) K (±10%)	24	12500 MHz	0.03 Ω	700 mA	250 MHz							
KQ0603 T TE 1N8 □	0	1.8 nH		16		0.045 Ω									
KQ0603 T TE 3N3 □	X	3.3 nH		20		6900 MHz			0.055 Ω						
KQ0603 T TE 3N6 □	E	3.6 nH							0.063 Ω						
KQ0603 T TE 3N9 □	1	3.9 nH							0.08 Ω						
KQ0603 T TE 4N3 □	F	4.3 nH							27	5900 MHz	0.063 Ω				
KQ0603 T TE 4N7 □	G	4.7 nH									0.116 Ω				
KQ0603 T TE 5N1 □	Y	5.1 nH									0.115 Ω				
KQ0603 T TE 6N8 □	2	6.8 nH									0.11 Ω				
KQ0603 T TE 7N5 □	H	7.5 nH									28	4800 MHz	0.106 Ω		
KQ0603 T TE 8N2 □	A	8.2 nH	0.12 Ω												
KQ0603 T TE 8N7 □	J	8.7 nH	0.109 Ω												
KQ0603 T TE 9N5 □	B	9.5 nH	31	4800 MHz	0.125 Ω										
KQ0603 T TE 10N □	3	10 nH			0.13 Ω										
KQ0603 T TE 11N □	K	11 nH			0.086 Ω										
KQ0603 T TE 12N □	4	12 nH			35	4000 MHz	0.13 Ω								
KQ0603 T TE 15N □	5	15 nH					0.17 Ω								
KQ0603 T TE 16N □	L	16 nH					0.104 Ω								
KQ0603 T TE 18N □	6	18 nH					0.17 Ω								
KQ0603 T TE 22N □	7	22 nH					37	3000 MHz	0.19 Ω						
KQ0603 T TE 23N □	S	23 nH							0.15 Ω						
KQ0603 T TE 24N □	M	24 nH							0.135 Ω						
KQ0603 T TE 27N □	8	27 nH	40	2800 MHz					0.22 Ω						
KQ0603 T TE 30N □	N	30 nH							0.144 Ω						
KQ0603 T TE 33N □	9	33 nH							40	2300 MHz	0.22 Ω				
KQ0603 T TE 36N □	P	36 nH			38	2080 MHz					0.25 Ω				
KQ0603 T TE 39N □	0	39 nH									40	2200 MHz	0.25 Ω		
KQ0603 T TE 43N □	Q	43 nH											39	2000 MHz	0.28 Ω
KQ0603 T TE 47N □	1	47 nH													38
KQ0603 T TE 51N □	T	51 nH					0.31 Ω								
KQ0603 T TE 56N □	2	56 nH					0.31 Ω								
KQ0603 T TE 68N □	3	68 nH					37	1700 MHz							
KQ0603 T TE 72N □	4	72 nH	0.49 Ω												
KQ0603 T TE 82N □	5	82 nH	34	1400 MHz											
KQ0603 T TE R10 □	6	100 nH							0.58 Ω						
KQ0603 T TE R11 □	7	110 nH			32	1350 MHz			0.61 Ω						
KQ0603 T TE R12 □	8	120 nH							0.65 Ω						
KQ0603 T TE R15 □	9	150 nH							25	1400 MHz	1.4 Ω				
KQ0603 T TE R18 □	0	180 nH									2.2 Ω				
KQ0603 T TE R20 □	U	200 nH									1200 MHz	2.3 Ω			
KQ0603 T TE R21 □	V	210 nH										130 mA			
KQ0603 T TE R22 □	1	220 nH					2.5 Ω								
KQ0603 T TE R25 □	W	250 nH					24	1000 MHz				2.4 Ω			
KQ0603 T TE R27 □	2	270 nH	170 mA												
KQ0603 T TE R30 □	X	300 nH	2.3 Ω												
KQ0603 T TE R33 □	3	330 nH	3.17 Ω												
KQ0603 T TE R39 □	4	390 nH	800 MHz	3.0 Ω											
KQ0603 T TE R47 □	5	470 nH	700 MHz	3.7 Ω											
KQ0603 T TE R51 □	V	510 nH	640 MHz	1.21 Ω											
KQ0603 T TE R56 □	6	560 nH	610 MHz	1.26 Ω											
KQ0603 T TE R62 □	W	620 nH	590 MHz	1.89 Ω											
KQ0603 T TE R68 □	7	680 nH	30	540 MHz	1.97 Ω										
KQ0603 T TE R75 □	X	750 nH			25	530 MHz	2.04 Ω								
KQ0603 T TE R82 □	8	820 nH					1200 MHz	2.5 Ω							
KQ0603 T TE R91 □	Y	910 nH					40	490 MHz	3.09 Ω						
KQ0603 T TE R1R0 □	9	1000 nH							1000 MHz	2.4 Ω					
KQ0603 T TE R1R2 □	0	1200 nH							900 MHz	2.3 Ω					
									840 MHz	3.17 Ω					
									800 MHz	3.0 Ω					
									700 MHz	3.7 Ω					
									640 MHz	1.21 Ω					
			610 MHz	1.26 Ω											
			560 MHz	2.09 Ω											
			590 MHz	1.89 Ω											
			540 MHz	1.97 Ω											
			530 MHz	2.04 Ω											
			490 MHz	3.09 Ω											
			480 MHz	2.95 Ω											
			440 MHz	5.13 Ω											
			400 MHz	5.45 Ω											

□ Enter the code for inductance tolerance (G, J, K)

TE = 2.000 pcs/reel

Please note, that the pattern and size of the pads may affect the Q-values. Please verify the actual using conditions.

Contact our sales representatives before you use our products for applications including automobiles, medical equipment and aerospace equipment. Malfunction or failure of the products in such applications may cause loss of human life or serious damage.

Specifications given herein may be changed at any time without prior notice. Please confirm technical specifications before you order or use.

INDUCTORS